



VENUS SERIES

Table of Contents

Main Components Bolt Torque Table.....	3
Grounding Path Diagram.....	4
Handling Instructions.....	5
Tool Requirement.....	6
Component List.....	7
Planning a Layout.....	8
Footing & Rail Installation.....	9
Splicing Rails.....	10
Module Mounting/End Clamp Installation.....	11
Module Mounting/Mid Clamp Installation.....	12
Grounding Installation.....	13
Micro-Inverter Installation.....	14

Note: This is for visual reference only, these components will not necessarily all be used together in a system.

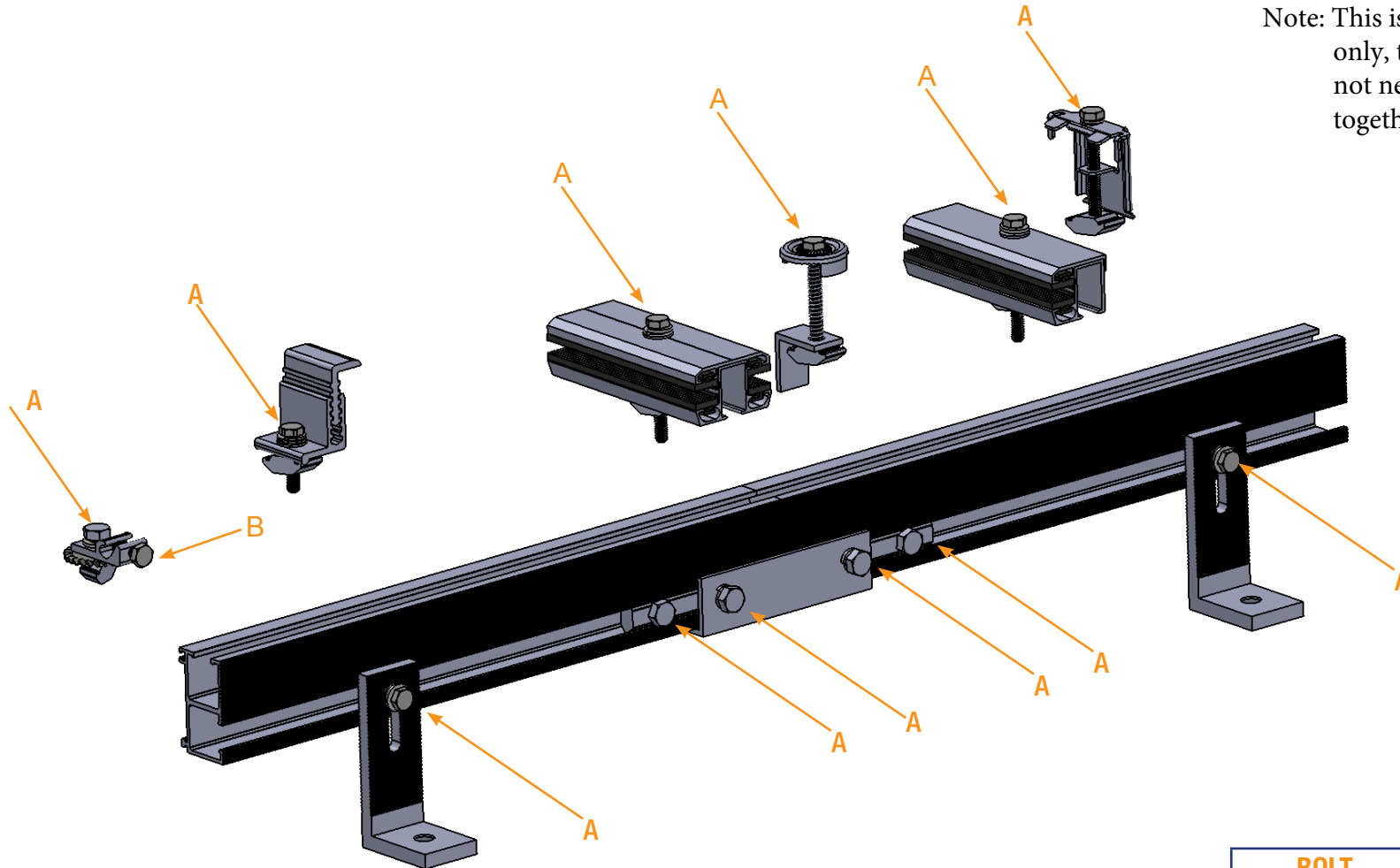

BOLT	TORQUE
A	75 in-lb
B	10-20 in-lb

Note: This is for visual reference only, these components will not necessarily all be used together in a system.

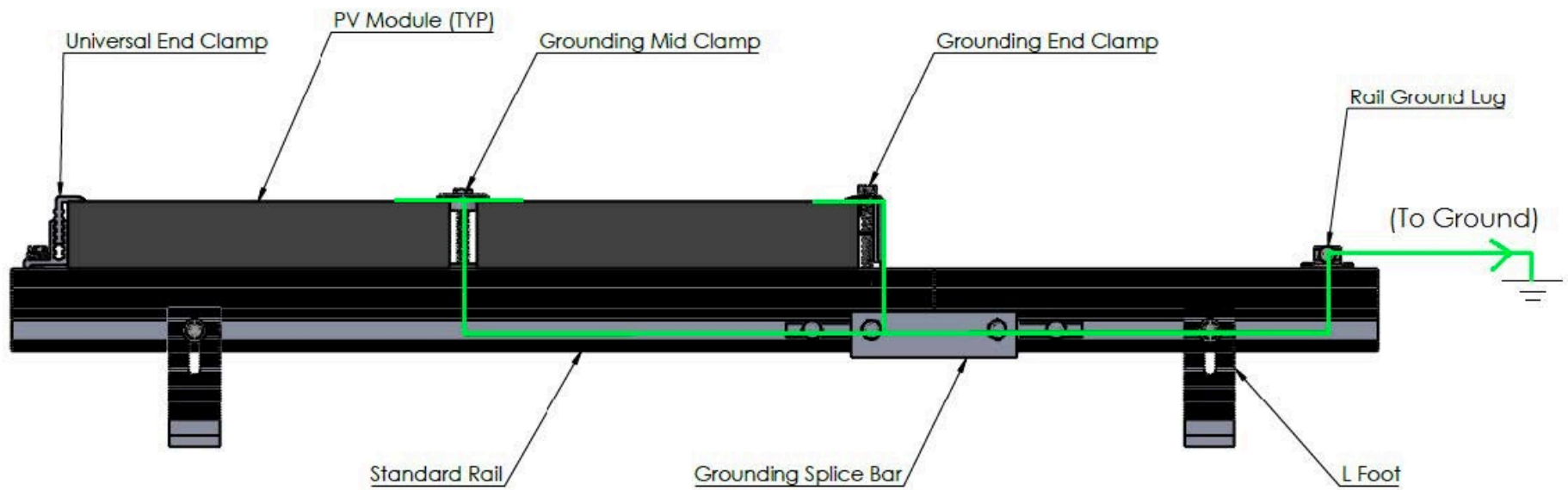

Our Company

Orion Solar Racking specializes in Engineering, designing, development and manufacturing of photo-voltaic Mounting solutions. Since its foundation Orion has released a wide range of quality and innovative mounting systems. We provide roof-mount; ground mount; Pole mount; single axis trackers; carports for Commercial, agriculture, industrial, government & educational as well as utility grade projects.

Each and every day we endeavor to make simple yet innovative solar racking solution, Orion provides LIVE technical support for all of distributors, dealers and contractors.

Here at OSR, you can trust our knowledge of installation, code compliance and necessary technical documentation to always be above the rest.

Online tools like our Web-estimator Video installation videos and our IN-House Research & design teams that are eager to help you solve your toughest construction challenges. We now play a leading role in the solar industry and have a rapidly gained recognition amongst system integrators, installers and distributors across the world.

Mission Statement

Our mission has always been to provide quality products and promote green renewable energy Solutions, that reduce our dependency on earth depleting methods that may contaminate our environment.

Panel Compatibility

The Orion Venus System is UL approved for the following PV Modules:
Amerisolar AS-6M 295-330Wp, Canadian Solar CS6X-310|315|320|325p, Hanwha HSL 72S Series (290-315W), Jinko JKM320p-72 (305-320W), LG 320N1C-G4, LG 335S2W-G4, Mitsubishi PV-MLE 280HD2, Panasonic HIT (325 & 330W), Suniva Optimus Series, Sunpower E20-327, Trina Tallmax 72 cell (305-320W), Winaico WSP-310M6

Handling & Installing Orion Solar Racking

It is critically important to observe standard safety practices when installing Orion Solar Racking:

- Stop work during stormy weather. Solar modules can be caught in the wind.
- Never step or sit on the glass surface of a solar module. The glass may break, resulting in shock or bodily injury.
- Do not throw or roughly handle any Orion Solar Racking components.
- Do not bring the Orion Solar Racking into contact with sharp or heavy objects.
- Do not modify Orion Solar Racking components in any way. The exchange of bolts, drilling of holes, bending and any other physical changes not intended in standard installation procedure will void the warranty.
- Product should be installed and maintained by qualified personnel. Keep unauthorized personnel away from solar modules.
- It is the installer's responsibility to verify the integrity of the structure to which Orion Solar Racking is fixed.
- Roofs or structures with rotten/ rusted bearers, undersized bearers, excessively spaced bearers or any other unsuitable substructure cannot be used with Orion Solar Racking, and installation on such structures could result in death or serious injury and will void the warranty.

Rail Calculation & Design

Rail calculations are based on code approved conventional mechanical section properties, material properties, stress equations, and allowable margins of safety. Beam calculations have been conservatively performed in non-snow areas with simply supported assumptions. Components have had full envelope forces from the tables applied to each component. This is prescriptive in nature and not a site specific engineering document for building permit application. Please visit our website (www.OrionRacking.com) or contact Orion Racking System for more detailed information and site specific engineering data on specific projects. ASCE7-10 guidance for wind is used in the tables.

Material Contact Warning!!

Grounding lugs, ground wire, and other material should be installed such that copper does not come into contact with aluminum or galvanized steel.



Caulking Gun w/ approved sealant



Chalk Line Reel



6mm & 8mm Metric Allen Key/ 6mm & 8mm Hexagonal Drive Bit



Construction Hart Hat



Construction Gloves



Adjustable Wrench



Drill with 7/32 Bit



Measuring Tape



7/16" & 1/2" Socket Head



Safety Harness



Roofing Bar



Torque Wrench

Before Installing

Caution: Refer to the section "Planning a Layout" before attempting installation. Failure to correctly establish the requirements of the proposed installation site is dangerous and will void the framing warranty.



Rail



Splice Bar



Small Mount Flashing



L-Foot



Flat Tile Hook



Spanish Tile Hook



Stand Off

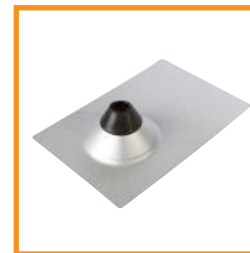

(High Rise) Flashing



Grounding End Clamp



(Universal) End Clamp



(Standing) Grounding Mid Clamp



Grounding Mid Clamp



Rail Ground Lug



SGB-5 Grounding Lug



Micro Inverter Grounding Clamp



Wire Management Clip

New Frameless Solution!



Frameless End Clamp



Frameless Mid Clamp



Note:

An Orion Racking Venus System can be identified by the Orion logo located on the Grounding Mid Clamp Cap as shown above.

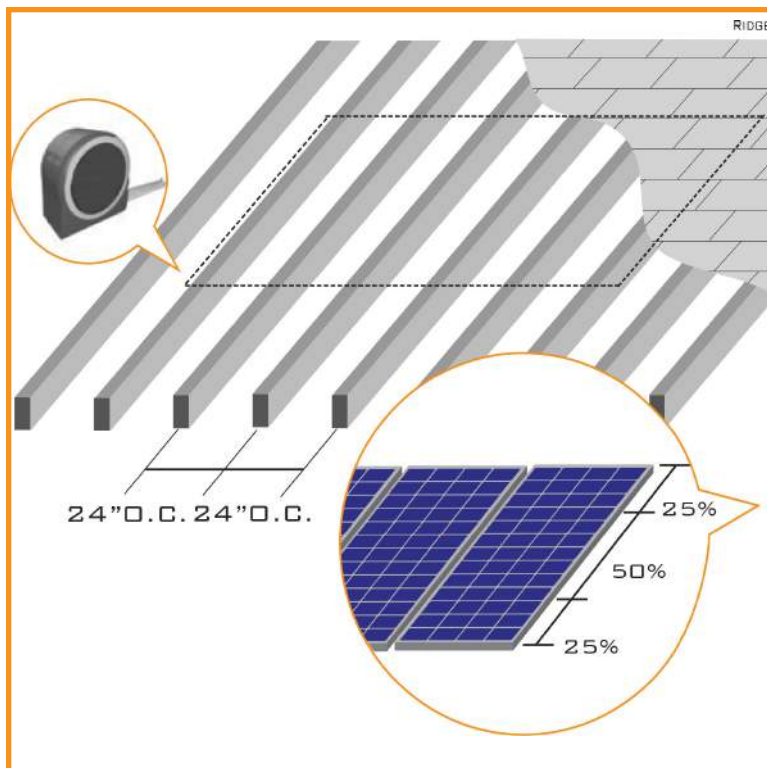

For Residential Roof Systems, rafters are typically located 16" O.C. or 24" O.C.

Once rafter spacing is determined, choose your attachment spacing.

Attachment spacing is recommended for STD Rail between 4' and 6' O.C.

Please check with your local jurisdiction codes.

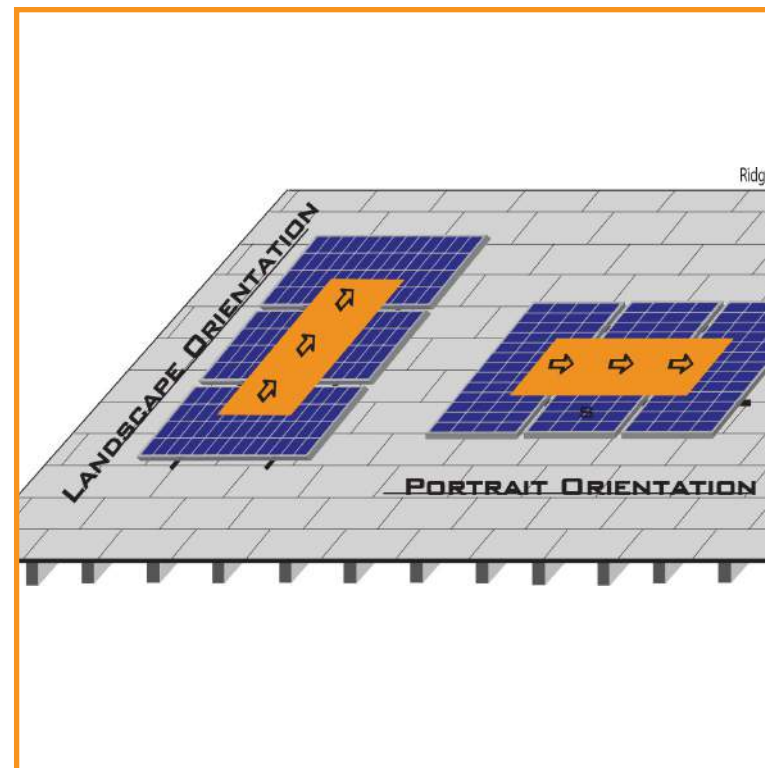

The layout can be set with rails parallel to the rafters or horizontal to the rafters.

Center the installation area over the structural members as much as possible and take Fire Dept. set-backs into consideration. (refer to local AHJ or NFPA).

Leave enough room to safely move around the array during installation. Some building codes require minimum clearances around HVAC and other roof top penetrations.

Remember! The rail length of installation equals: the total width of the modules.

- Plus 3/4" for each mid clamp
- Plus 2" for each pair of end clamps.



Snap horizontal and vertical chalk lines to mark rafter position and attachment points.

At marked locations, drill pilot holes with 7/32 Drill Bit.

While drilling into rafter, keep drill bit at a 90° angle in relationship to the rafter.

For maximum strength, pilot hole should not be more than 3 inches in depth to avoid splitting the roof rafter or truss member.

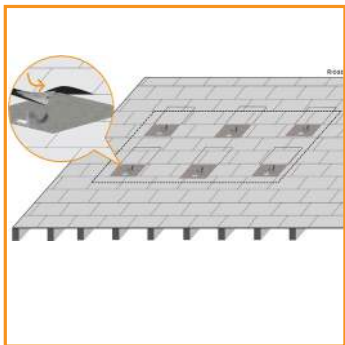

Make sure the washer on the threaded shank is positioned correctly.

Use a roofer bar to lift the roof shingle.

Slide the flashing under shingles until the hole lines up with the Orion Shoe (roughly 1.5 shingles deep).

To prevent roof leaks, insert the flashing on the threaded shank of the Orion Shoe as shown.

Repeat steps for all attachments.

Apply roof sealant under flashing.

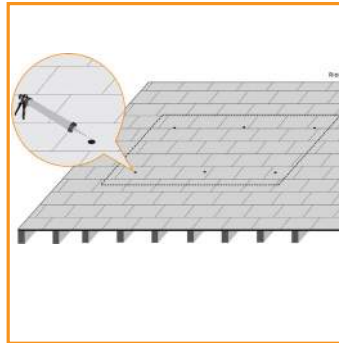

De-Burr and Clean dust off and fill pilot hole with approved roofing sealant (please refer to local AHJ).

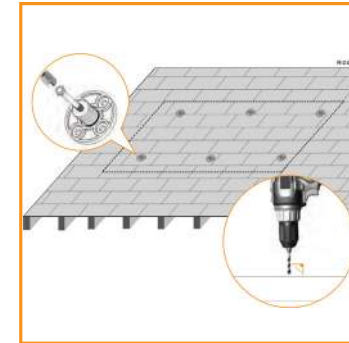

Using a 1/2" socket head, drill the 5/16" lag bolt through the "Orion Shoe" and into the center of the rafter.

Do not over tighten.

When drilling the rafter, keep the drill bit at a 90° angle in relationship to the rafter.

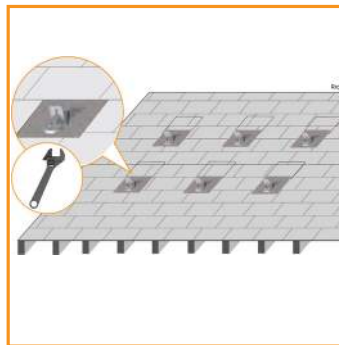

Insert the L-Foot to the "Orion Shoe" on top of the flashing.

Place hex cap on shoe, and tighten cap.

Use 180 in-lbs nominal torque when tightening hex cap.

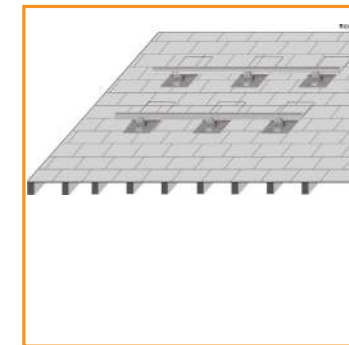

Attach Orion rail to L-Foot by inserting/tilting channel nut into the side opening of the rail.

Push rail into channel nut.

Align rail, channel nut and 1/4-20 bolt.

Tighten to 75 in-lbs.

Note:

The maximum cantilever of rail from nearest attachment point is 12 in.

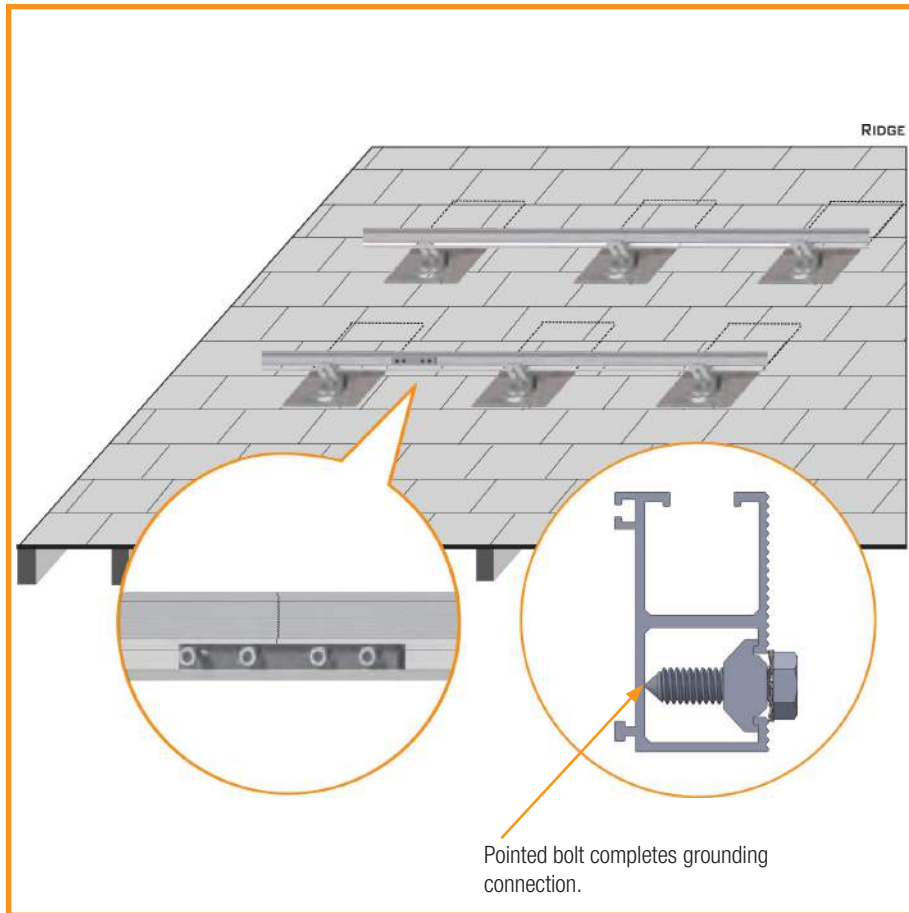

Use splice bars when expanding rail lengths, within 18" of L-Feet or Stand-Offs splice rails by inserting splice bar into side channel or opening.

Tighten 1/4-20 bolts to a minimum of 75 in-lbs nominal torque (same for rail splice).

Grounding Splice Bar



Align rails end to end



Slide over Splice Bar so 2 bolts cover each rail



75 in-lb torque

Rail to Rail Splice

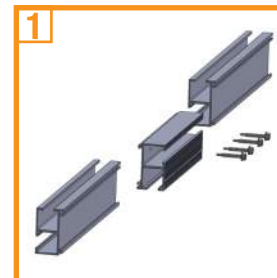

Align rails end to end with "splice" section facing "backwards & upside-down"

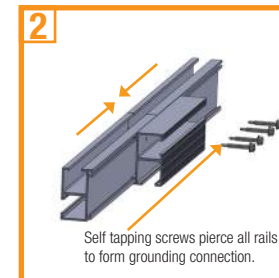

Slide tongue & groove section through "splicing" rail so half spans each rail

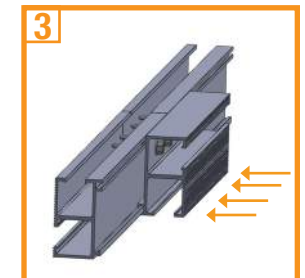

56 in-lb torque

Note:

Grounding Splice Bars and Rail-to-Rail Splice are Single Use Only at a specific point on the Rail. If re-installation is necessary, the Rail must be shifted such that the pointed bolts of the Grounding Splice Bar touch a new area of the Rail.

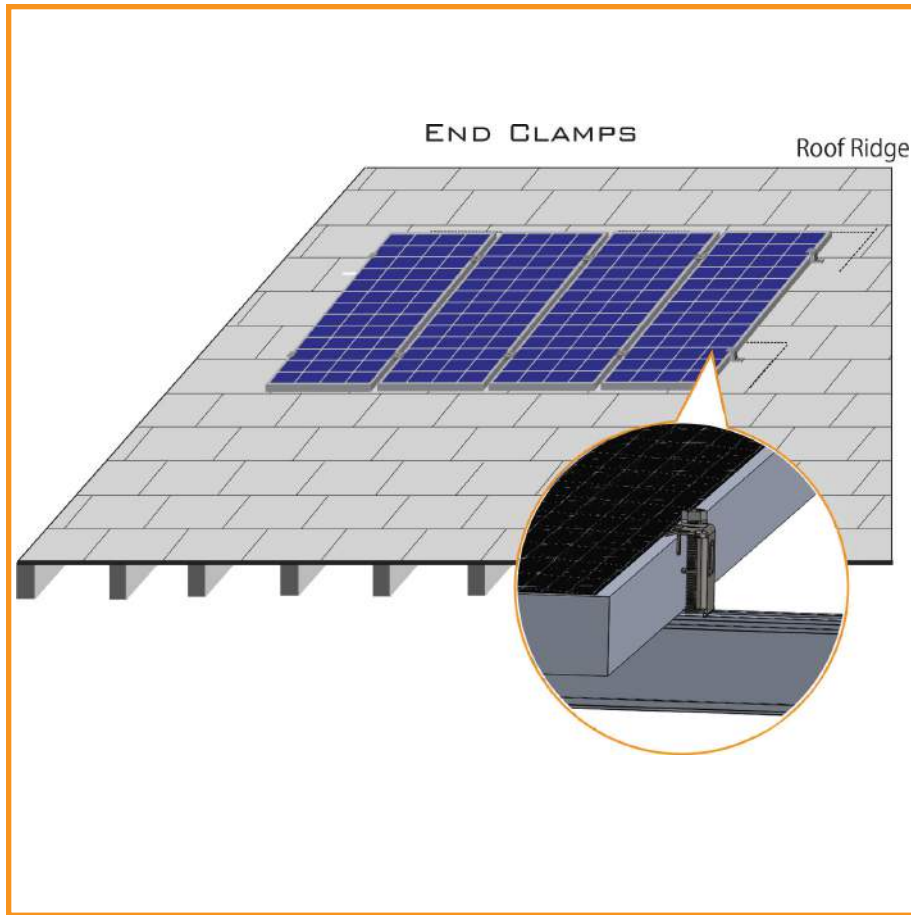

Use End clamps at end of PV modules.

Set Orion End Clamp by mounting into the top channel opening of Orion Rail.

Tighten 1/4-20 bolts to 75 in-lbs nominal torque.

Orion Racking carries universal end clamps for module frame sizes 30mm to 50mm or module size specific grounding end clamps.

Grounding End Clamp Method

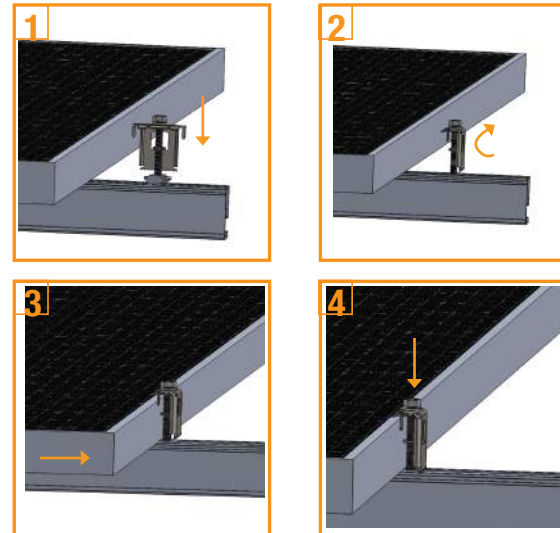

Note:

Grounding End Clamps are Single Use Only at a specific point on the PV Module. If re-installation is necessary, the PV Module must be shifted such that the Grounding End Clamp touches a new area of the frame.

75 in-lb

Universal End Clamp Method

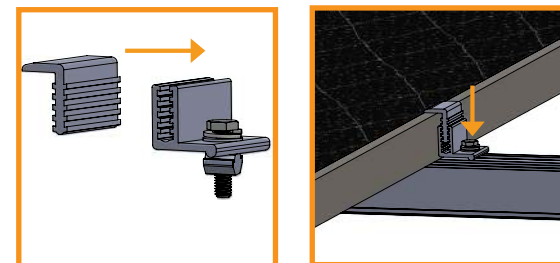

Slide top section into base at correct height for your panel.

75 in-lb

Frameless End Clamp Method

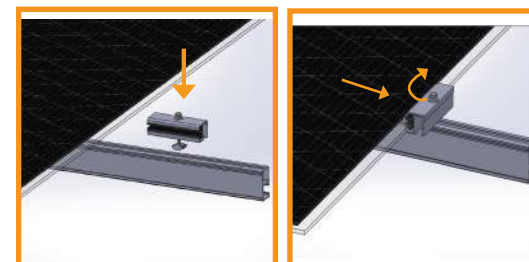

75 in-lb

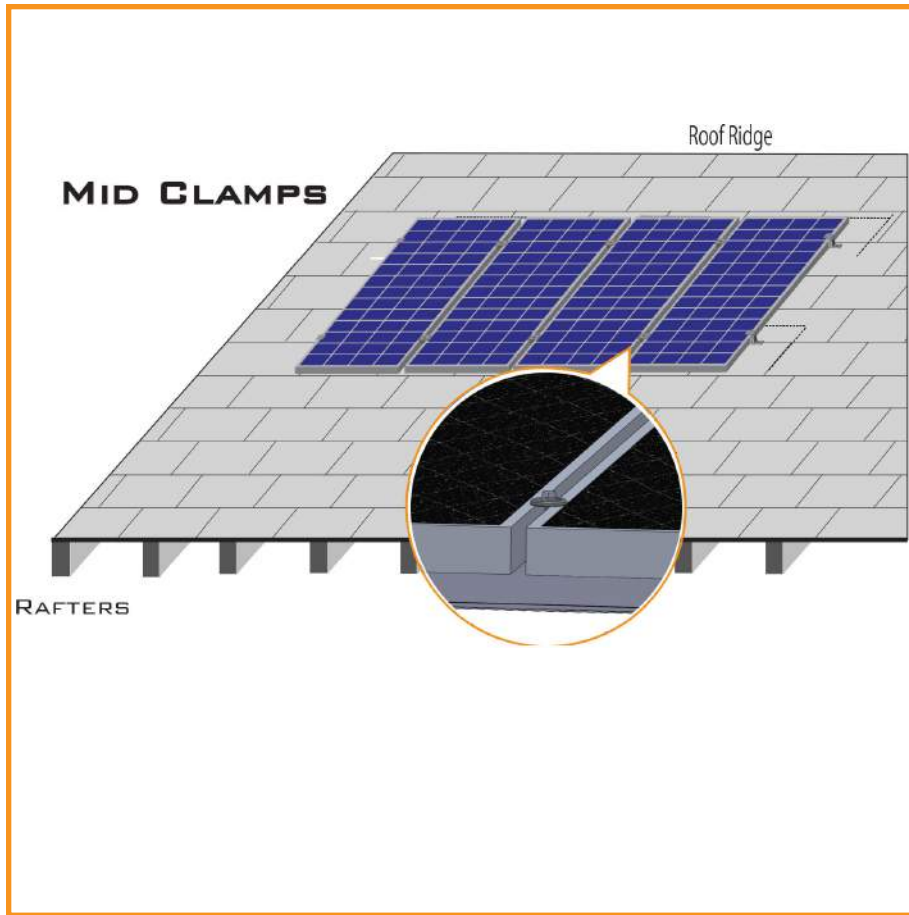

Place mid clamps in between modules at suggested span per module manufacturer's specifications.

Attach mid clamps by mounting onto the top and bottom opening of Orion Rail to Orion Channel nut, or slide in nut in to the channel from the side to desired install position.

Tighten 1/4-20 bolts to 75 in-lbs nominal torque.

Installation Mid Clamps

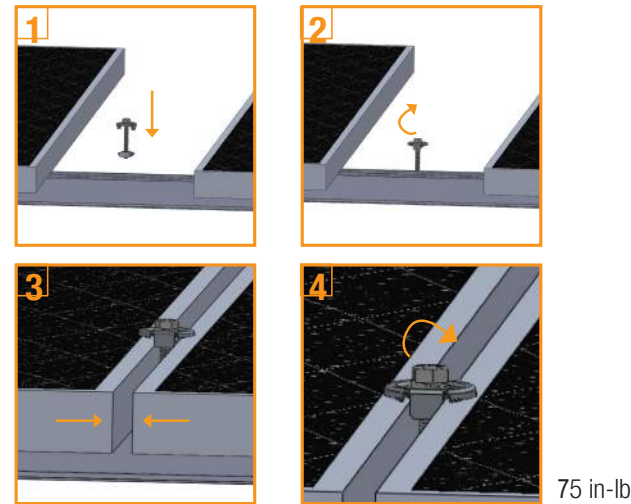

Note:

Grounding Mid Clamps are Single Use Only at a specific point on the PV Module. If re-installation is necessary, the PV Module must be shifted such that the Grounding Mid Clamp touches a new area of the frame.

Spring Standing Mid Clamp

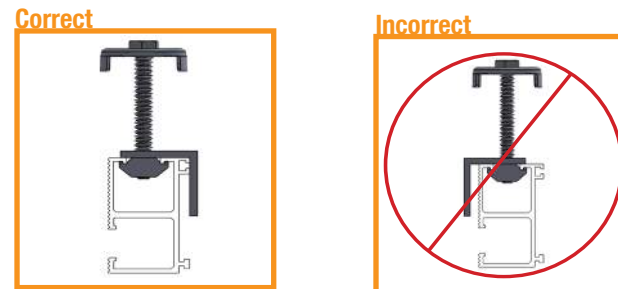

Angle should fit snugly over "back" of Orion Rail.

Frameless Mid Clamp Method



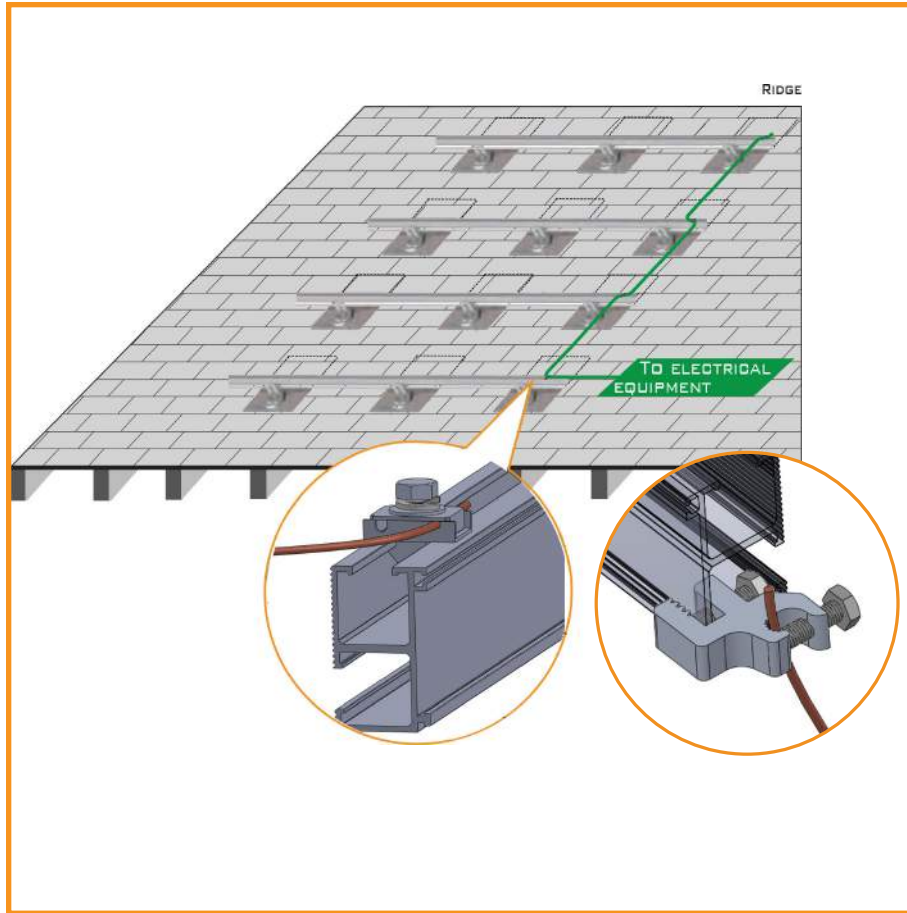

Use a ground lug to create a continuous ground from rail to rail terminating at the grounding rod or main service panel.

Run grounding wire from furthest ground lug through each ground lug to electrical equipment or grounding rod.

Lay in equipment ground conductor and torque bolt to suggested nominal torque.

Select ground wire based on plan layout.

Installing Smart Ground Clip

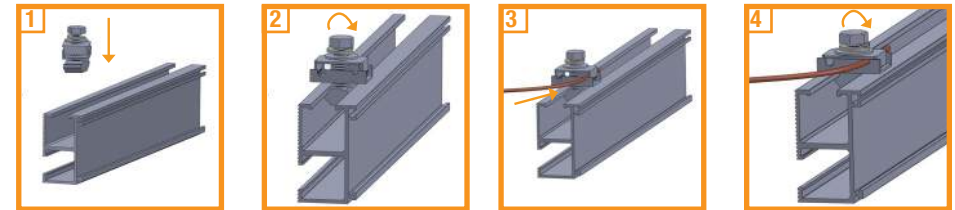

35 in-lb torque

Installing SGB-5 Ground Lug

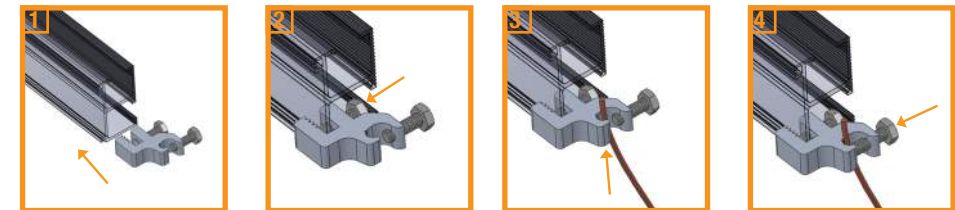

10-20 in-lb torque

10-20 in-lb torque

Installing Rail Ground Lug

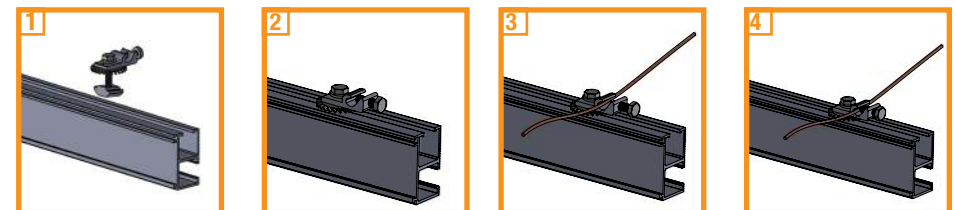

75 in-lb torque

10-20 in-lb torque

Note:

Grounding Lugs are Single Use Only at a specific point on the Rail. If re-installation is necessary, the Grounding Lug must be shifted such that the Grounding Lug touches a new area of the Rail.

Material Contact Warning!!

Grounding lugs, ground wire, and other material should be installed such that copper does not come into contact with aluminum or galvanized steel.

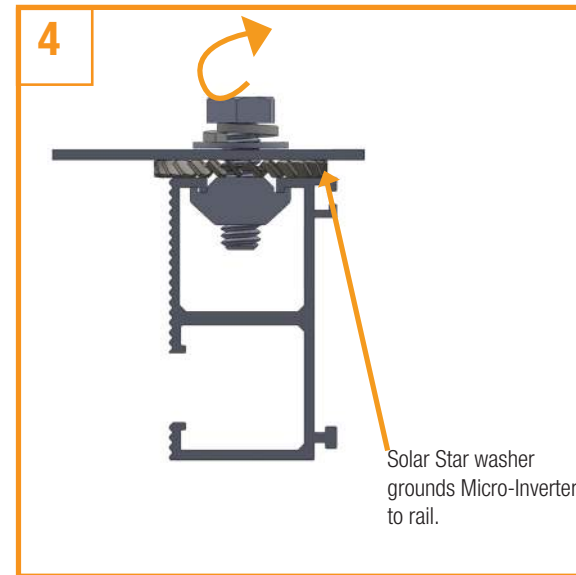
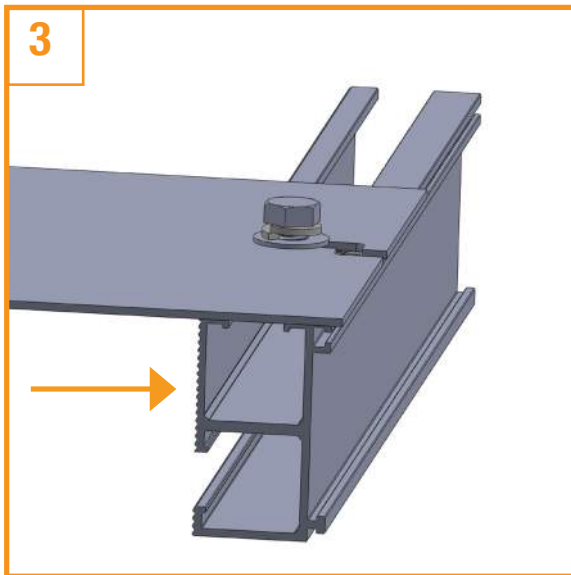
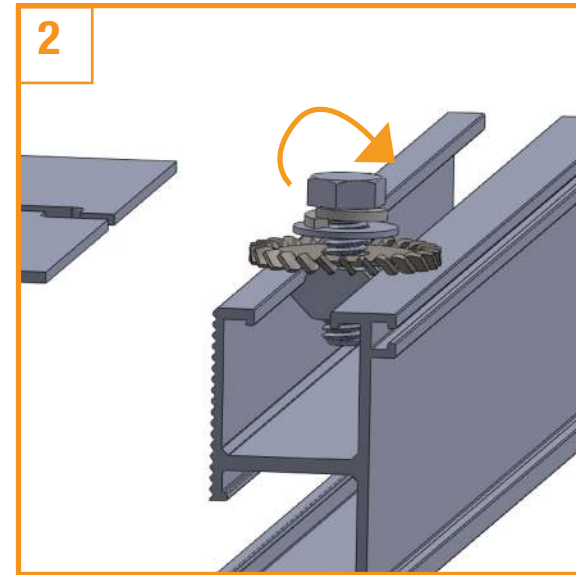
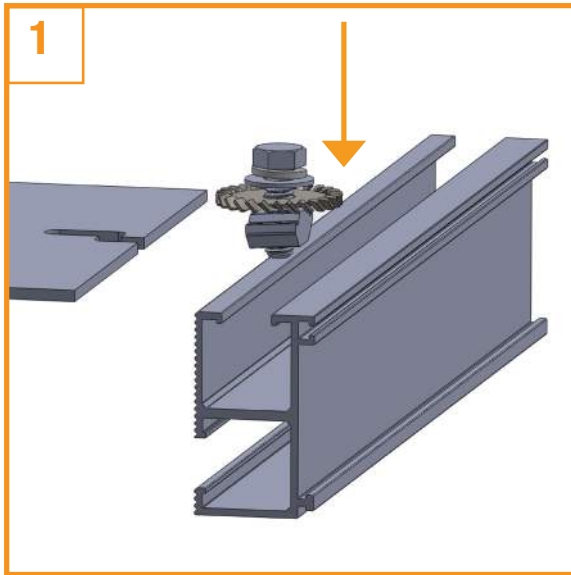

75 in-lb torque

Note:

Micro-Inverter Mounting T-Bolt Assemblies are Single Use Only at a specific point on the Rail. If re-installation is necessary, the Micro-Inverter must be shifted such that the Micro-Inverter Mounting T-Bolt Assembly touches a new area of the Rail.